

01_Description

Date: A2286_R6_1.kicad_sch

02_CPU Section

Date: A2286_R6_2.kicad_sch

03_FE3000 CPU Controller

Date: A2286_R6_3.kicad_sch

04_FE3010 DMA Controller

Date: A2286_R6_4.kicad_sch

05_IO Decoding + Buffer

Date: A2286_R6_5.kicad_sch

06_Address Bus Latches Buffer

Date: A2286_R6_6.kicad_sch

07_Data Bus Latches Buffer

Date: A2286_R6_7.kicad_sch

08_128k Dual Ported RAM

Date: A2286_R6_8.kicad_sch

09_Address Bus Translator

Date: A2286_R6_9.kicad_sch

10_Data Bus Translator

Date: A2286_R6_10.kicad_sch

11_Conn. to PC, AT, A2000 Bus

Date: A2286_R6_11.kicad_sch

12_Connectors to Baby Board

Date: A2286_R6_12.kicad_sch

13_Block Caps

Date: A2286_R6_13.kicad_sch

Sheet: /		
File: A2286_R6.kicad_sch		
Title:		
Size: A3	Date: 2024-03-30	Rev:
KiCad E.D.A. 8.0.4	Id: 1/14	

Schematic A2286 Rev.6

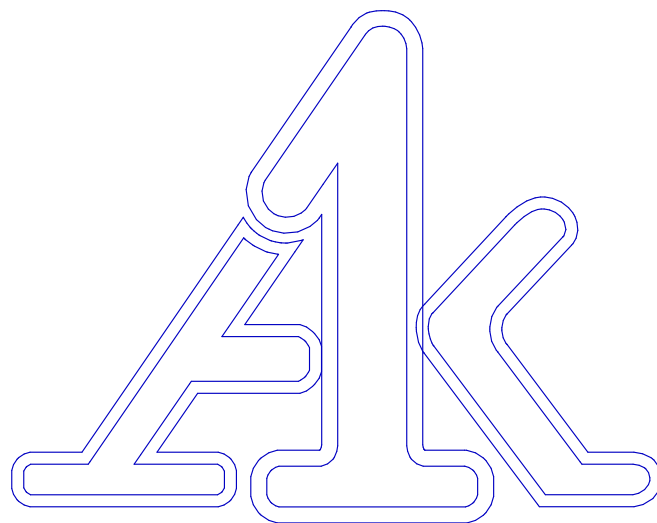

rework GONZO/A1k

Description

Sheet: /01_Description/
File: A2286_R6_1.kicad_sch

Title:

Size: User Date: 2024-03-30

KiCad E.D.A. 8.0.4

Rev:
Id: 1/14

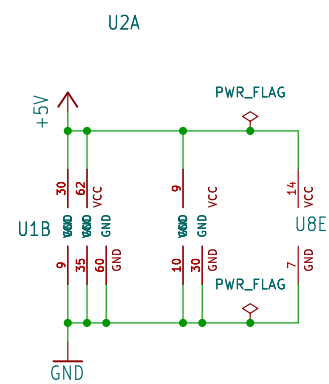
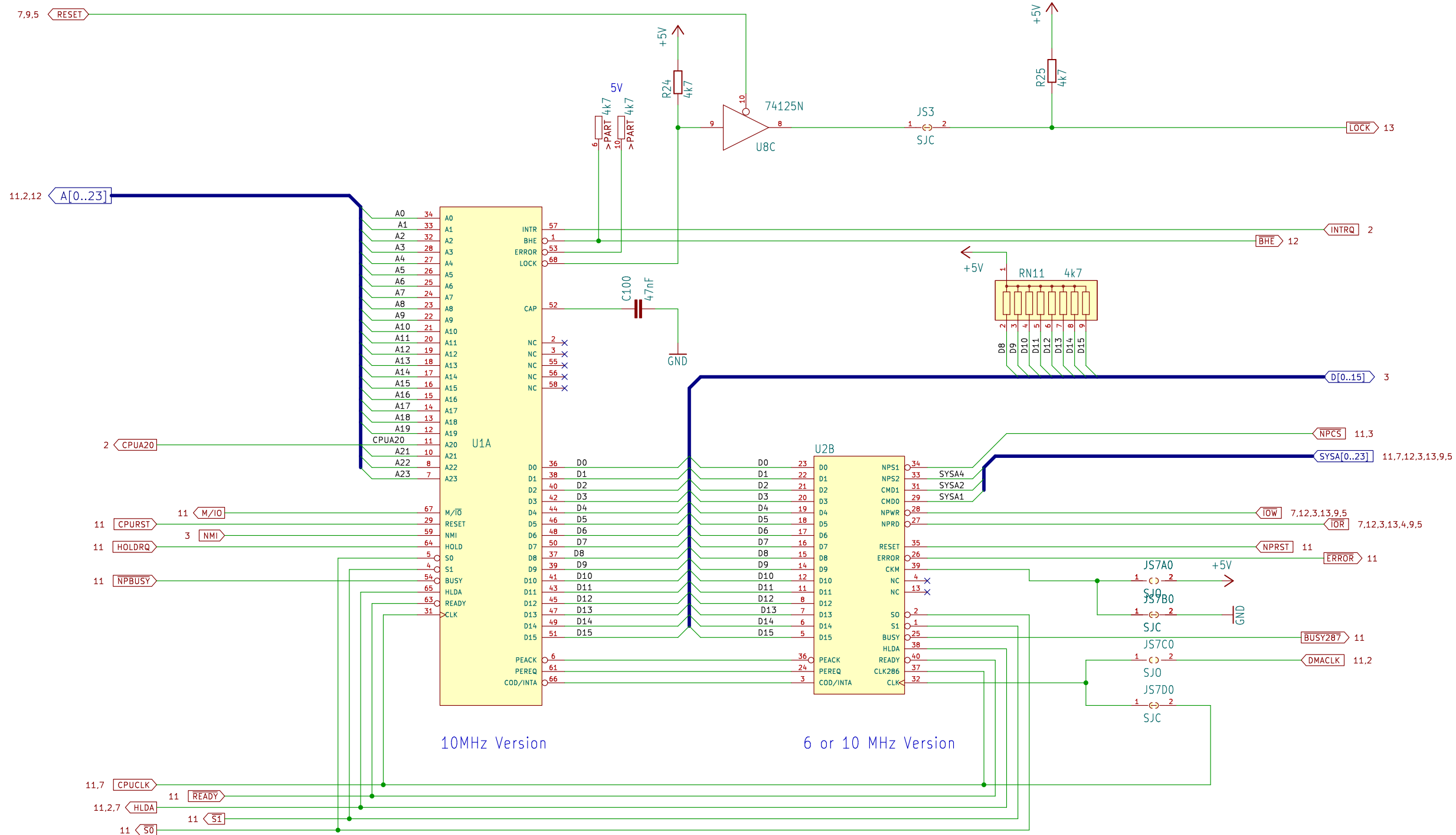

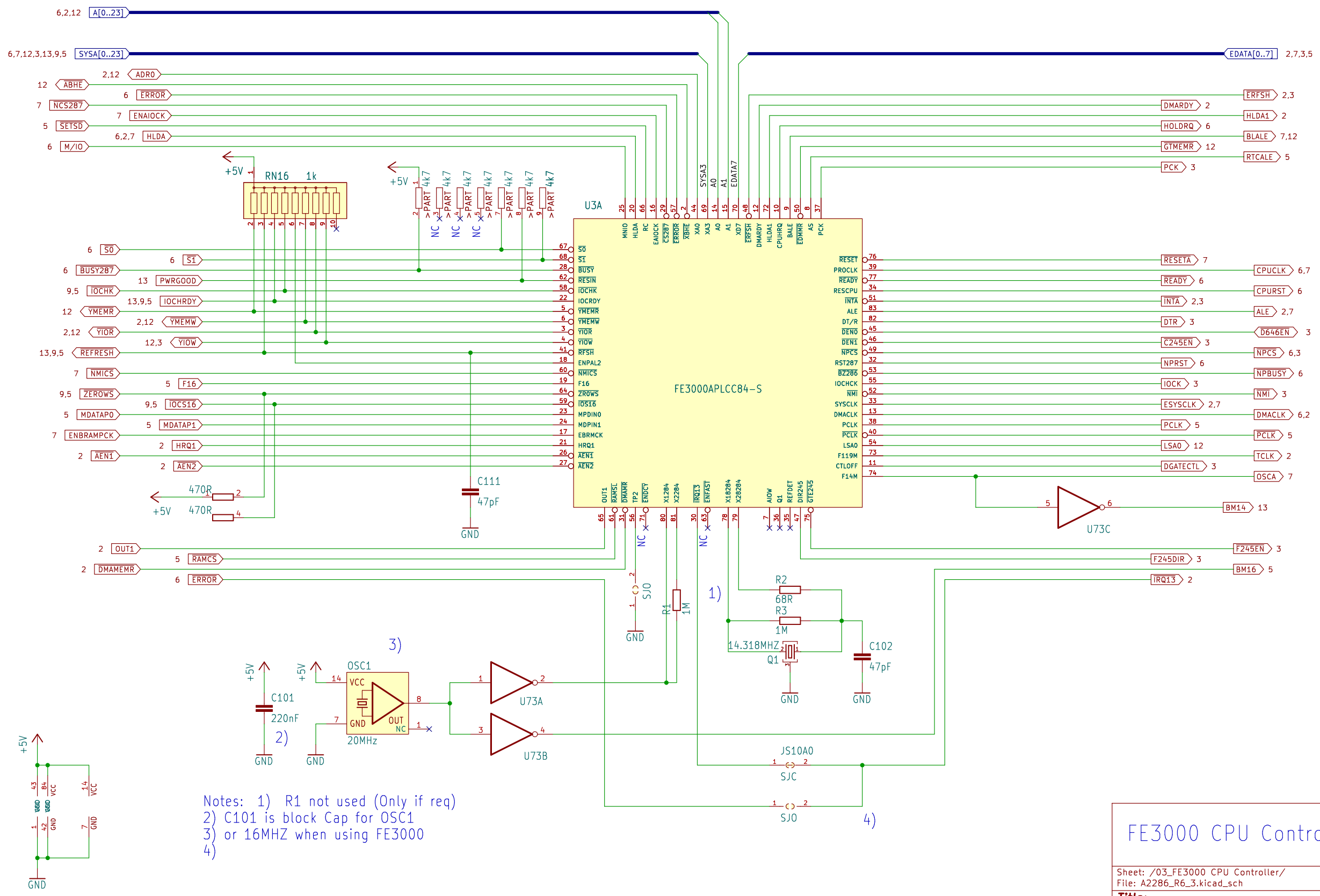

Notes: 1) R1 not used (Only if req)
 2) C101 is block Cap for OSC1
 3) or 16MHZ when using FE3000
 4)

FE3000 CPU Controller			6
Sheet: /03_FE3000 CPU Controller/			
File: A2286_R6_3.kicad_sch			
Title:			
Size: User	Date: 2024-03-30	Rev:	
KiCad E.D.A. 8.0.4		Id: 3/14	

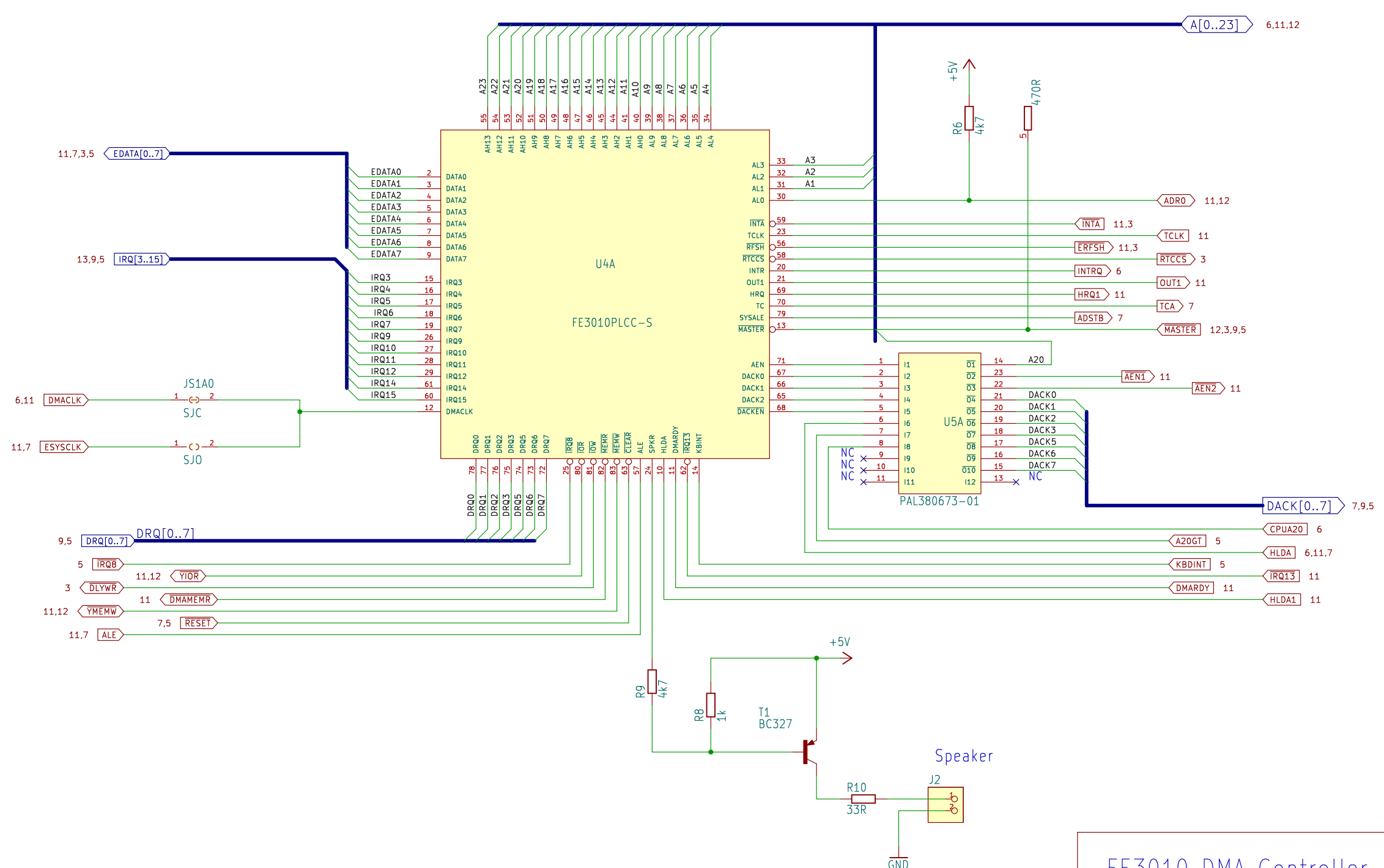
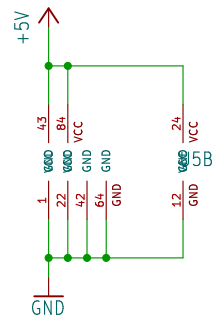

FE3010 DMA Controller

Sheet: /04_FE3010 DMA Controller/
File: A2286_R6_4.kicad_sch

Title:			
Size: User	Date: 2024-03-30	Rev:	
KiCad E.D.A. 8.0.4		Id: 4/14	

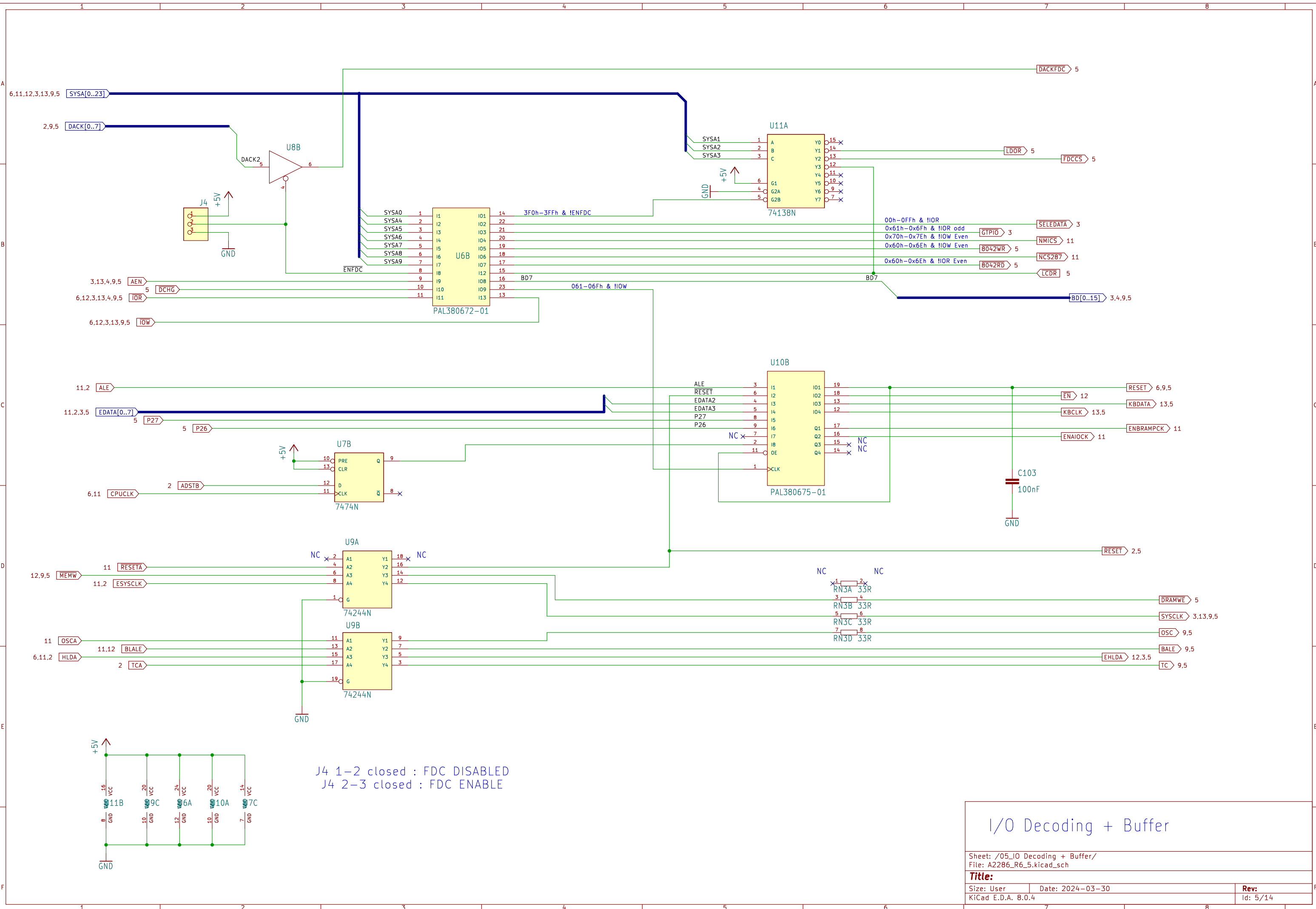

I/O Decoding + Buffer

Sheet: /05_IO Decoding + Buffer/
 File: A2286_R6_5.kicad_sch

Title:

Size: User	Date: 2024-03-30	Rev:
KiCad E.D.A. 8.0.4		Id: 5/14

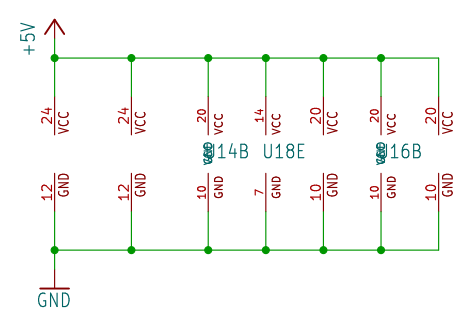
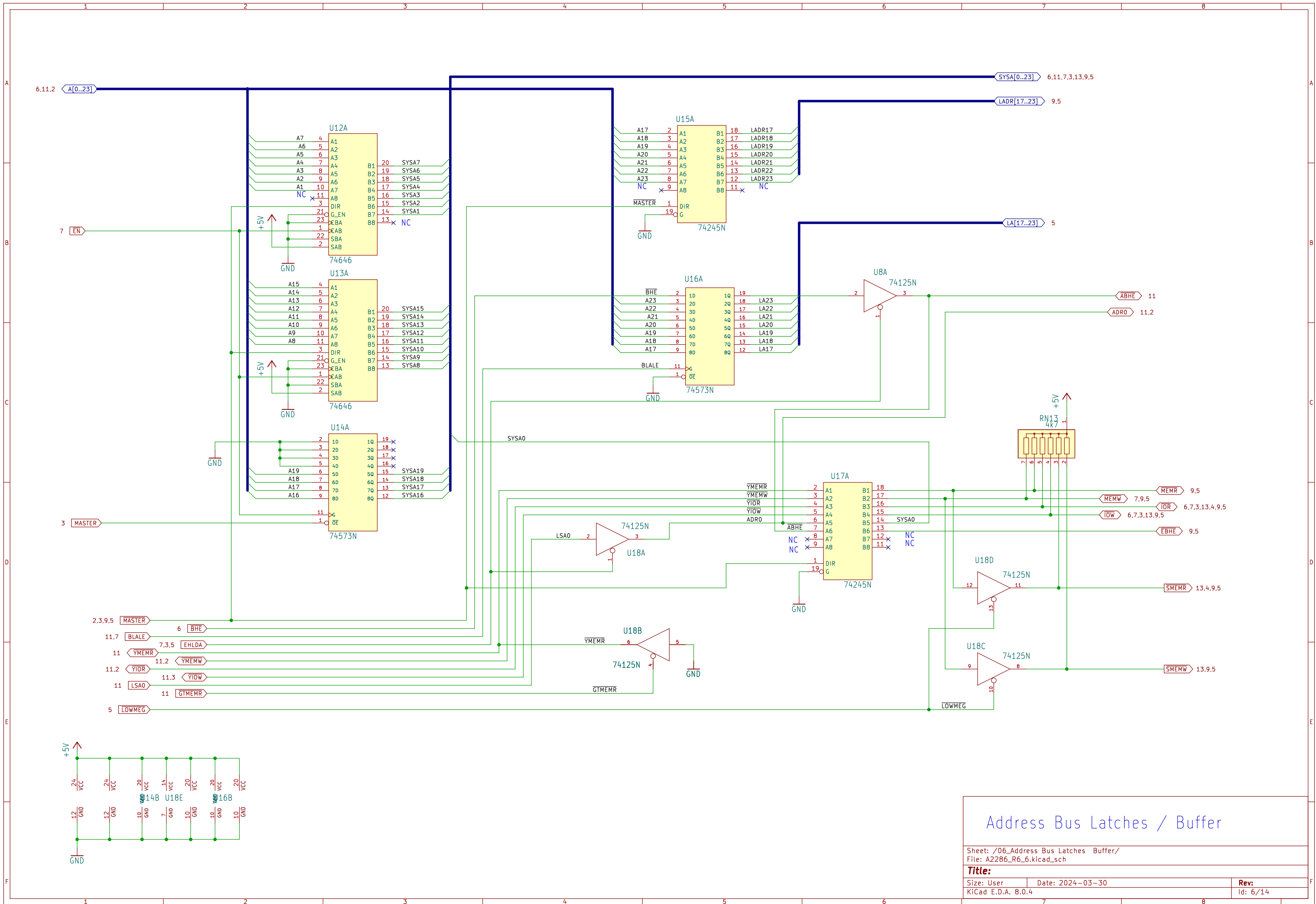

Address Bus Latches / Buffer

Sheet: /06_Address Bus Latches Buffer/
 File: A2286_R6_6.kicad_sch

Title:

Size: User	Date: 2024-03-30	Rev:
KiCad E.D.A. 8.0.4		Id: 6/14

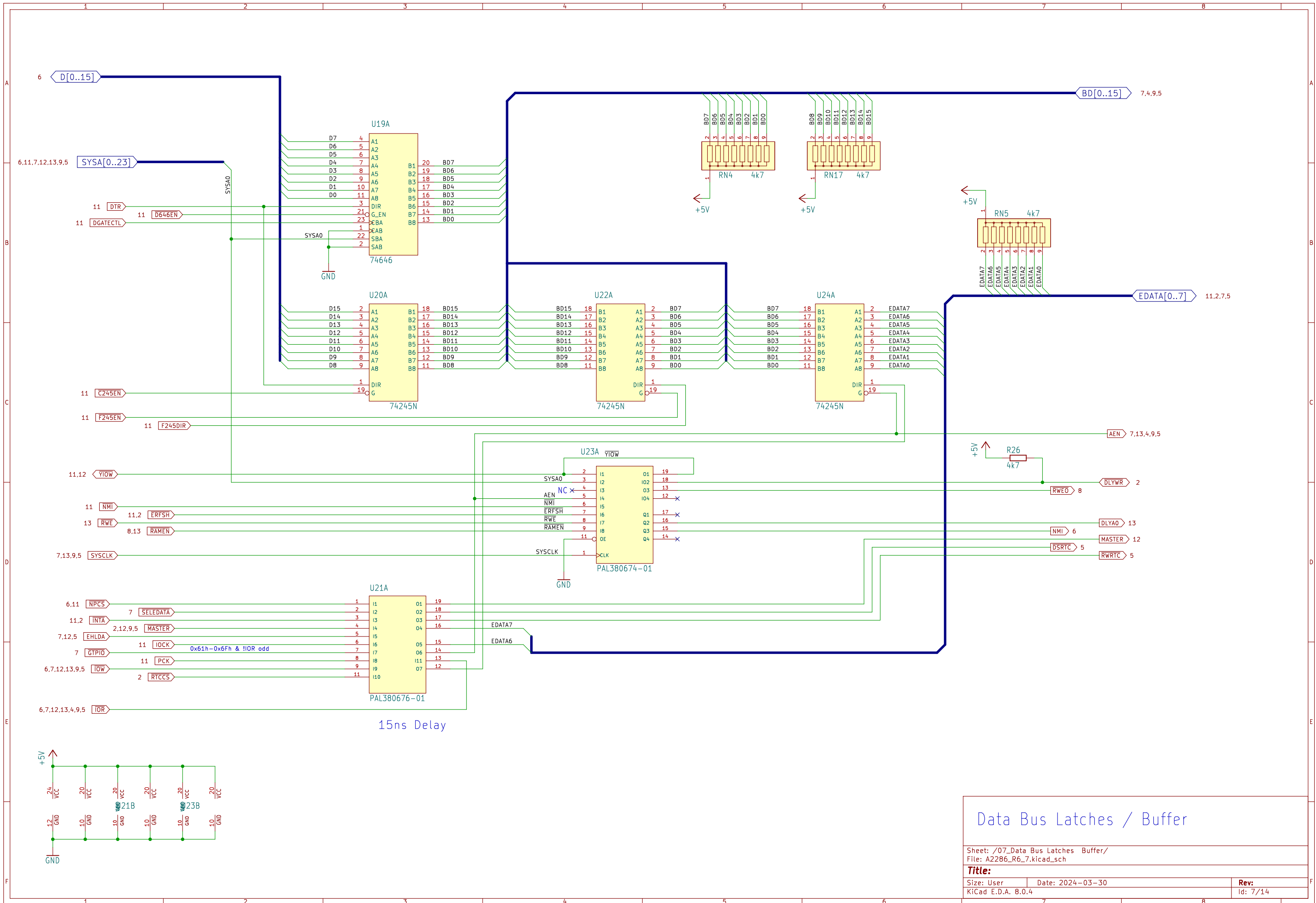

15ns Delay

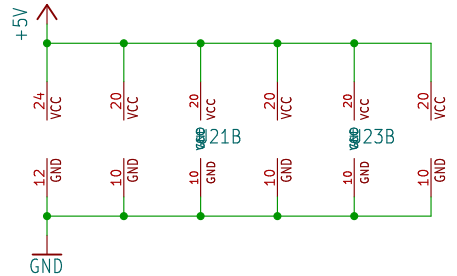

Data Bus Latches / Buffer

Sheet: /07_Data Bus Latches / Buffer/
 File: A2286_R6_7.kicad_sch

Title:

Size: User	Date: 2024-03-30	Rev:
KiCad E.D.A. 8.0.4		Id: 7/14

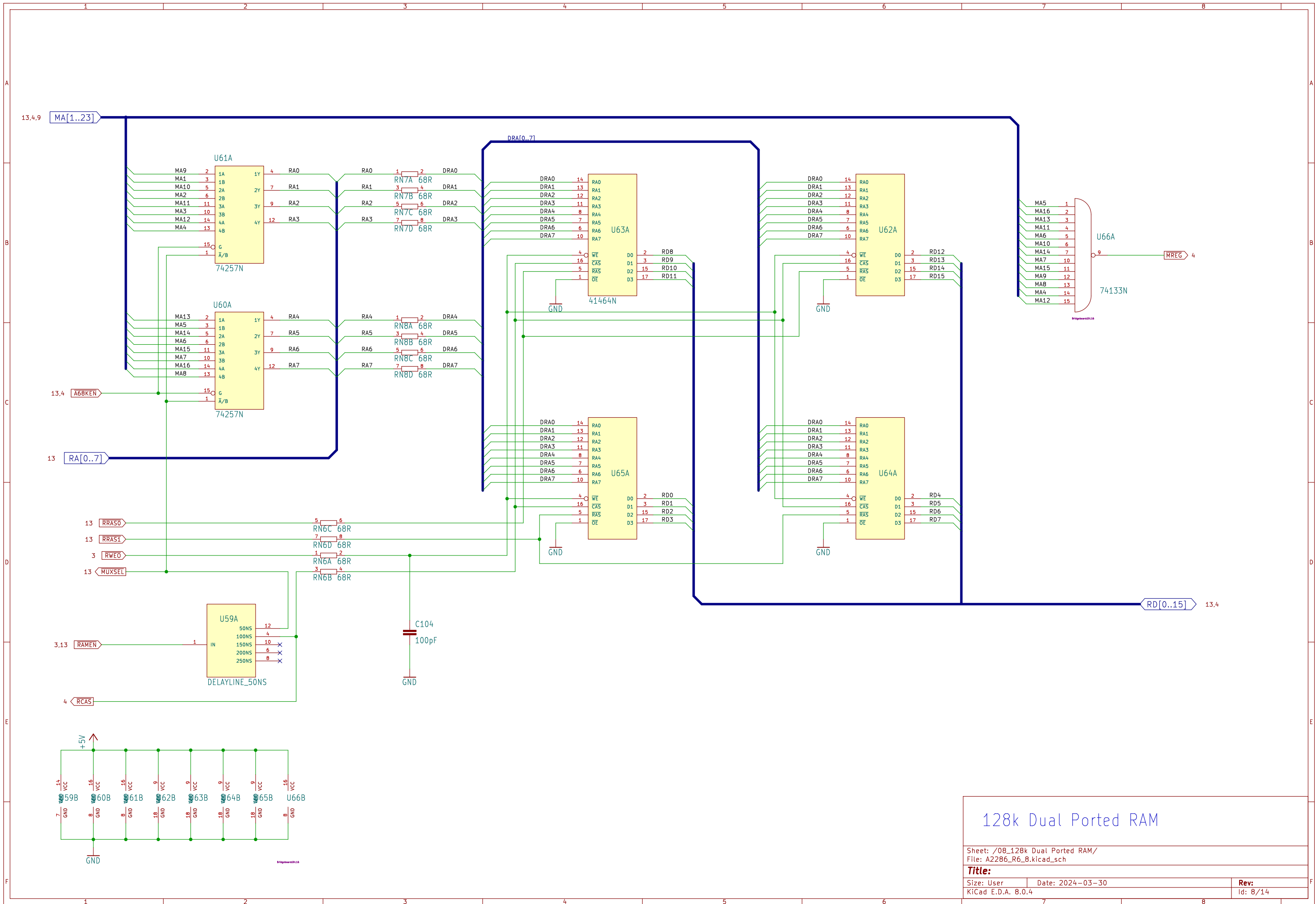

128k Dual Ported RAM

Sheet: /08_128k Dual Ported RAM/
 File: A2286_R6_8.kicad_sch

Title:

Size: User	Date: 2024-03-30	Rev:
KiCad E.D.A. 8.0.4		Id: 8/14

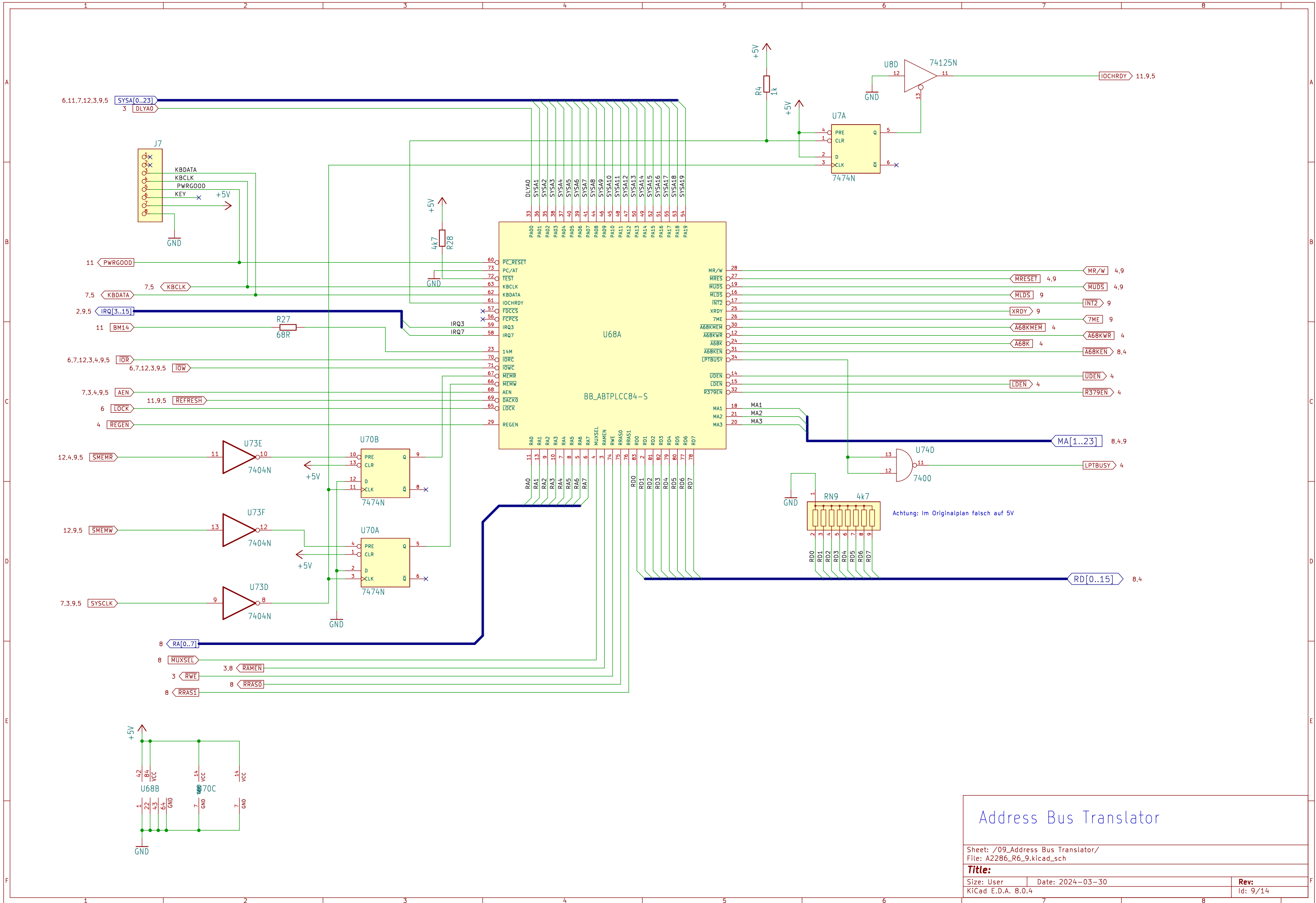

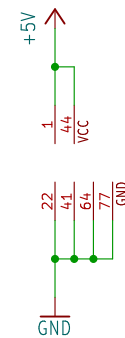
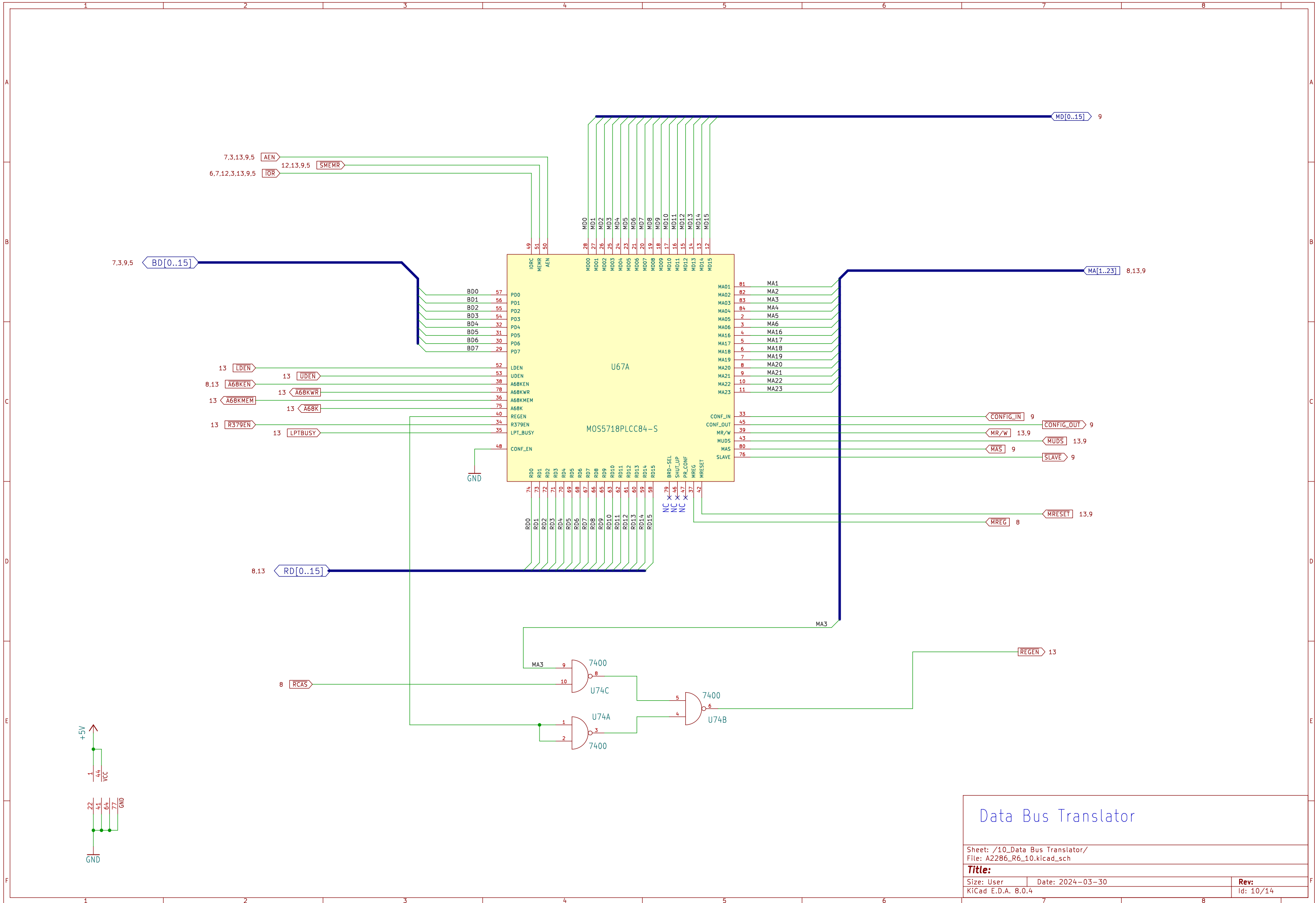

Data Bus Translator

Sheet: /10_Data Bus Translator/
 File: A2286_R6_10.kicad_sch

Title:

Size: User	Date: 2024-03-30
KiCad E.D.A. 8.0.4	Rev: 10/14

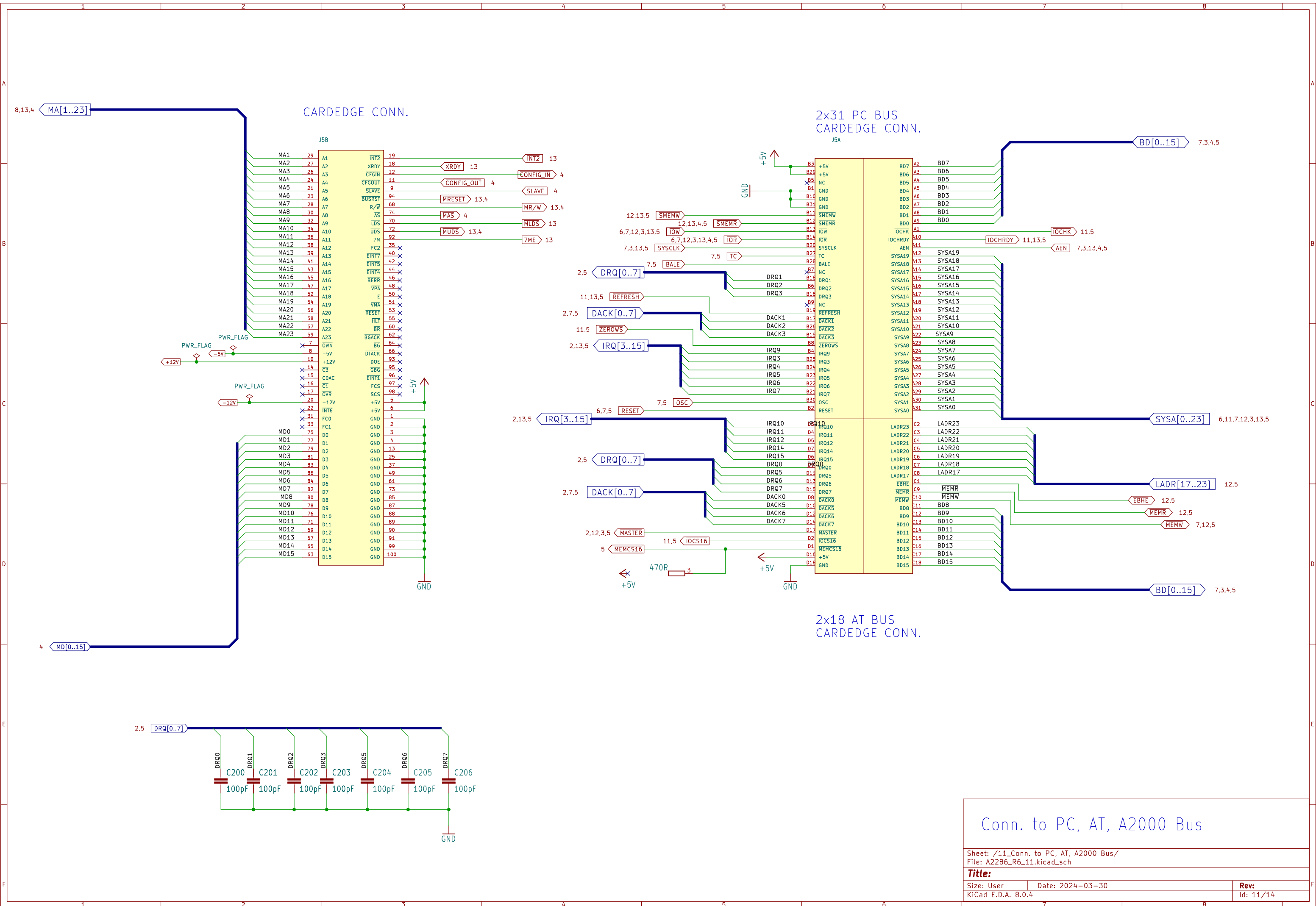

Conn. to PC, AT, A2000 Bus

Sheet: /11_Conn. to PC, AT, A2000 Bus/
 File: A2286_R6_11.kicad_sch

Title:

Size: User	Date: 2024-03-30	Rev:
KiCad E.D.A. 8.0.4		Id: 11/14

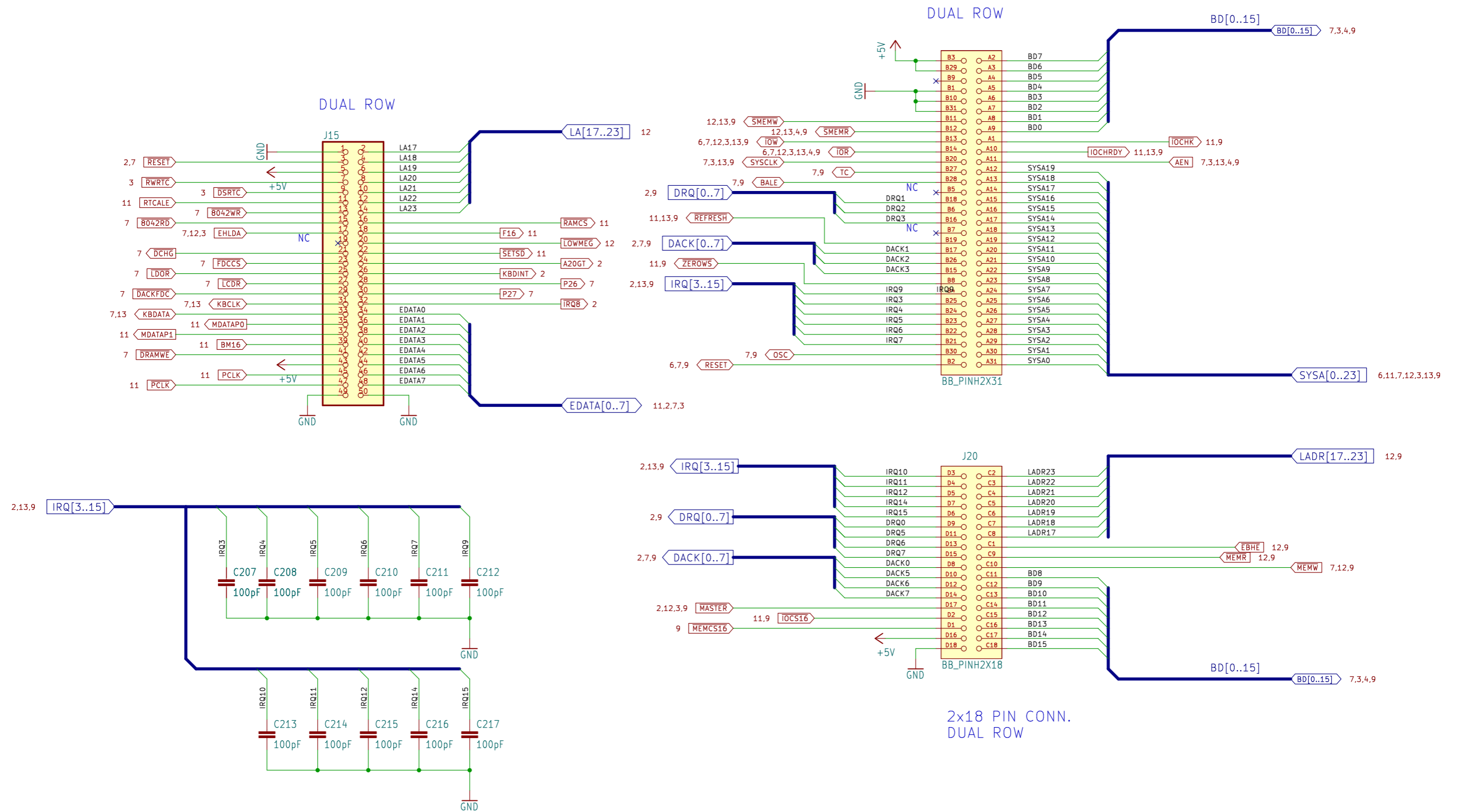

Connectors to Baby Board

Sheet: /12_Connectors to Baby Board/
File: A2286_R6_12.kicad_sch

Title:

Size: A3 Date: 2024-03-30
KiCad E.D.A. 8.0.4

Rev:
Id: 12/14

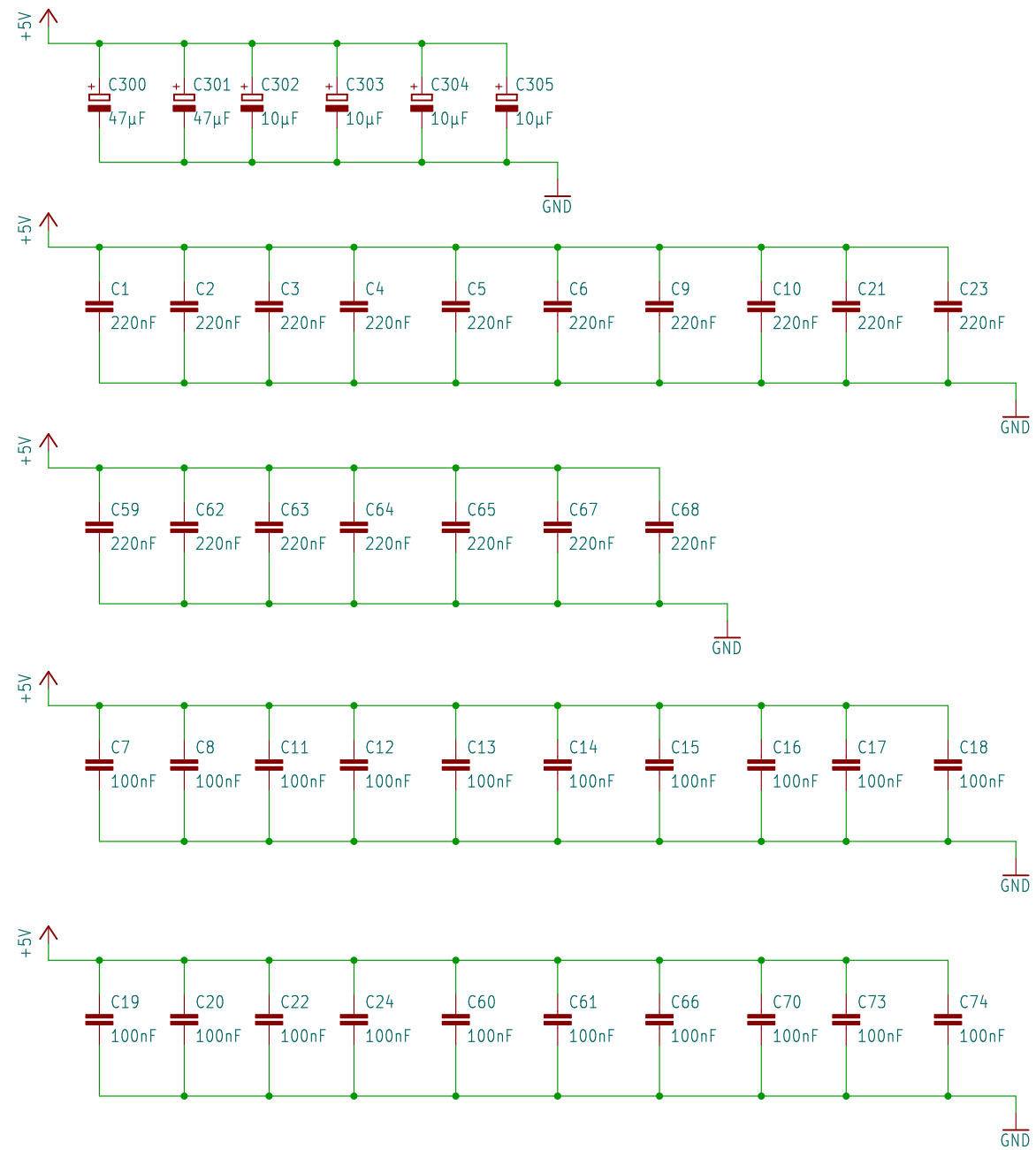

Block Caps 5V:
 2 x 47µF / 16V
 4 x 10µF / 16V
 17 x 220nF
 20 x 100nF

Block Caps

Sheet: /13_Block Caps/
 File: A2286_R6_13.kicad_sch

Title:

Size: User Date: 2024-03-30

Rev:
 Id: 13/14